



常规系列 (General purpose) DJM12100(12V100Ah)

规格 Specifications

额定电压 Rated Voltage	12V	
标称容量 Nominal Capacity(C ₁₀ , 1.80V/cell)	100Ah	
尺寸 Dimension	长 Length	330±2mm (12.99 in.)
	宽 Width	173±2mm (6.81 in.)
	高 Container Height	212±2mm (8.35 in.)
	总高(含端子) Total Height	220±2mm (8.66 in.)
重量 Approx Weight	30.6kg (67.5 lbs)	
端子 Terminal	M8	
外壳材料 Container Material	ABS	
额定容量 Rated Capacity (25°C)	105.0Ah	C20(5.25A, 1.80V/cell)
	100.0 Ah	C10(10.0A, 1.80V/cell)
	89.0 Ah	C5(17.8A, 1.75V/cell)
	77.1 Ah	C3(25.7A, 1.75V/cell)
	63.9 Ah	C1(63.9A, 1.67V/cell)
5S最大放电电流 Max. Discharge Current	1000A (5s)	
内阻 Internal Resistance (25°C)	Approx 4.9mΩ	
运行温度 Operating Temp. Range	放电 Discharge	-20 ~ 55°C (-4 ~ 131°F)
	充电 Charge	0 ~ 40°C (32 ~ 104°F)
	存储 Storage	-15 ~ 50°C (5 ~ 122°F)
推荐温度 Nominal Operating Temp. Range	25±5°C (77±5°F)	
最大充电电流(25°C) Max. Charging Current	30.0A	
充电电压(25°C) Charge voltage	浮充 Float	13.5V
	温度补偿 Temp. Coefficient	-3mV/单格/°C
	循环(均充) Cycle(Equalization)	14.1~14.4V
温度对容量影响 Effect of temp. to Capacity	40°C (104°F)	106%
	25°C (77°F)	100%
	0°C (32°F)	86%
自放电 Self Discharge	≤3%/月 @ 25°C	



外形 Layout

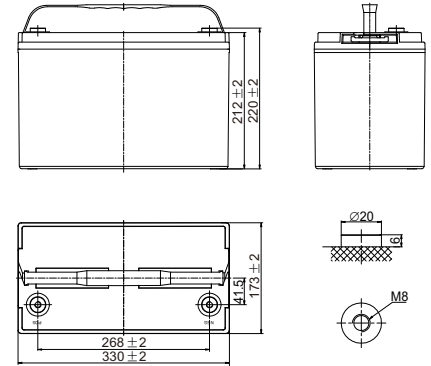

恒流放电表(A) 25 °C Constant Current Discharge

F.V/Time	15min	20min	30min	1h	1.5h	2h	3h	4h	5h	8h	10h	20h
1.85V/cell	152.8	119.2	82.5	52.5	35.5	29.9	23.8	19.4	16.6	11.7	9.39	4.93
1.80V/cell	170.3	132.8	92.0	55.6	37.5	31.5	25.0	20.3	17.2	12.0	10.0	5.25
1.75V/cell	177.7	138.6	96.0	59.0	39.7	33.0	25.7	21.1	17.8	12.2	10.2	5.36
1.70V/cell	179.9	140.3	97.2	61.7	41.5	34.2	26.5	21.6	18.1	12.4	10.3	5.41
1.67V/cell	182.7	142.5	98.7	63.9	42.9	35.2	27.3	22.1	18.4	12.6	10.4	5.46
1.60V/cell	185.5	144.7	100.2	64.6	44.0	35.8	27.8	22.4	18.7	12.7	10.5	5.51

恒功率放电表(W) 25 °C Constant Power Discharge

F.V/Time	15min	20min	30min	1h	1.5h	2h	3h	4h	5h	8h	10h	20h
1.85V/cell	280.1	218.5	151.3	84.4	64.3	52.9	40.4	33.2	30.4	20.0	16.7	8.79
1.80V/cell	312.2	243.5	168.6	90.7	69.3	57.1	43.3	35.1	32.2	20.7	17.0	8.94
1.75V/cell	325.8	254.1	175.9	95.4	72.3	59.3	44.6	36.3	33.2	21.0	17.2	9.04
1.70V/cell	329.9	257.3	178.1	99.7	74.8	60.9	45.8	37.2	33.9	21.1	17.4	9.14
1.67V/cell	335.0	261.3	180.9	104.1	77.5	62.6	47.2	38.2	34.3	21.3	17.6	9.24
1.60V/cell	340.0	265.2	183.6	108.2	79.9	63.9	48.1	38.7	34.7	21.7	17.9	9.40



常规系列 (General purpose) DJM12100(12V100Ah)

应用 Applications

- 通讯
Telecommunications
- UPS、数据中心
UPS、Data Center
- 储能、电力
Energy Storage、Electric Systems
- 紧急照明、安防
Emergency Lighting、Security
- 医疗、电子设备
Medical、Electronic Equipment
- 动力
Motive Power

特征 General Features

- 25°C下, 设计浮充寿命可达12年。
Under 25°C, the designed floating life is up to 12 years.
- 特殊的排气结构和密封技术, 使用安全可靠, 安装灵活, 维护便捷。
Special exhaust structure and sealing technology, safe and reliable, flexible installation, convenient maintenance.

标准 Standards

- 符合IEC 60896, GB/T19638, YD/T 799 和DL/T 637标准
Compliance with IEC 60896, GB/T19638, YD/T 799 and DL/T 637 standards
- UL 认证, 泰尔认证
UL Certified, TLC Certified
- 企业通过了TS16949, OHSAS 18001, ISO 9001和ISO 14001体系认证
Manufactured in Leoch®TS16949, OHSAS 18001, ISO 9001 and ISO 14001 certified production facilities

放电特性曲线 Discharge Characteristics

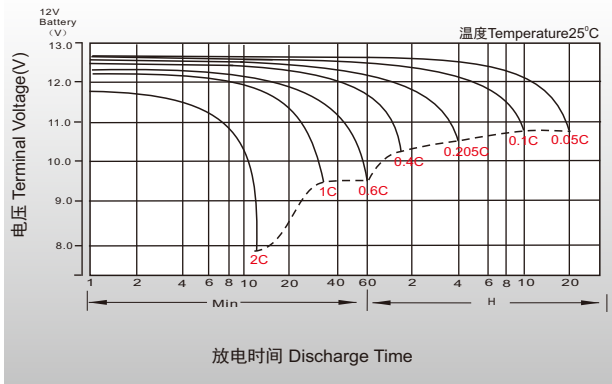

浮充特性曲线 Float Charging Characteristics

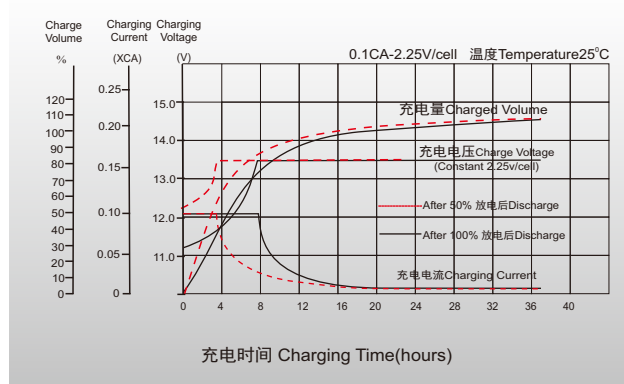

温度对容量影响 Temperature Effects in Relation to Battery Capacity

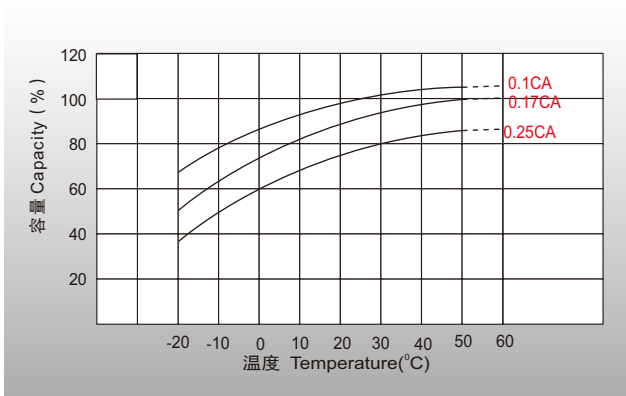

温度对浮充寿命影响 Temperature Effects on Long Term Float Life

